

7. 电器/Electric Device

序号/ No.	名 称 / Designation	页 码 /Page No.
7,01	油水分离附加电线(2200)/Additional wire oil-water separation	1
7,02	H0W0-TFT屏组合仪表(燃油)/Combination instrument	2
7,03	V7G电气接线盒铭牌/Nameplate	3
7,04	H0W0中央电气控制系统(NanoBCU 矿车)/Central electric control system	4
7,05	70矿车HW7C电器装置/Electrical device	5
7,06	倒车蜂鸣器(矿车)/Buzzer	7
7,07	底盘电器(3个阀/矿车/D20)/Chassis electrical device	8
7,08	矿用车前照灯(右置)/Head light	9
7,09	蓄电池(180安-时)/180AH Battery	10
7,10	70矿用车电瓶箱/Battery box	11
7,11	车架电线束(970)/Frame the electrical harnesses	13
7,12	发动机线束、ABS线束进线装置/Engine cable harness	14
7,13	起动机电线(D20/1110/左置)/Starter wiring harness	15
7,14	艾利逊变速箱取力器线/PTO wiring harness	16
7,15	艾力逊变速箱线束/Transmission wire	17
7,16	右置尾灯电线束/Wring harness	18
7,17	差速锁电线(双桥30)/Diff. Lock Wireness	19
7,18	70矿车底盘电线(艾利逊箱/D20/TFT仪表/右置)/Chassis wiring harness	20

7.19	70矿车驾驶室电线(TFT仪表/D20/艾利逊箱/右置)/Cab wiring harness		21
7.20	非组合尾灯电线束(120/230带蜂鸣器/矿车)/Wiring harness		23
7.21	70矿车驾驶室电器设备/ Cab Electric Device		24
7.22	带侧标志灯的组合后灯/Combination lamp		26
7.23	非组合后灯(矿车专用/泰国/四倒车灯)/Light		27

7.04 HOWO中央电气控制系统 (NanoBCU 矿车) /Central electric control s

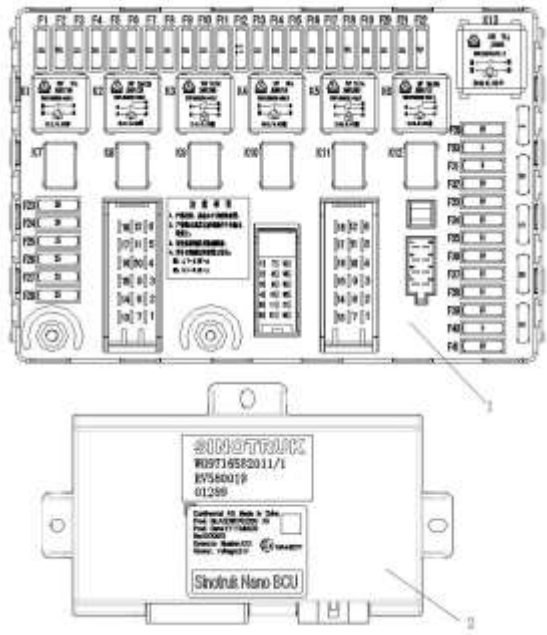

7.04 HOWO中央电气控制系统 (NanoBCU 矿车) /Central electric control s

序号	零部件图号	名称	Part Name	数量	备注
No.	Part No.			Qty	Remark
1	WG9716582301	电气接线盒总成	Box	1	
2	WG9716582011	NanoBCU控制器	BCU control unit	1	
3	Q2140612	十字槽盘头螺钉	Screw	4	
4	Q40306	弹簧垫圈	Spring washer	4	
5	Q40106	平垫圈	Washer	4	
6	Q2140510	十字槽盘头螺钉	Screw	1	
7	Q40305	弹簧垫圈	Spring washer	1	
8	Q40105	平垫圈	Washer	1	
9	Q2140610	十字槽盘头螺钉	Screw	1	
10	Q40306	弹簧垫圈	Spring washer	1	
11	Q40106	平垫圈	Washer	1	
12	WG9750580003	电器接线盒支架	Box bracket	2	
13	Q40206	大垫圈	Washer	4	
14	Q40306	弹簧垫圈	Spring washer	4	
15	Q340B06	I型六角螺母	Nut	4	
16	Q2140620	十字槽盘头螺钉	Screw	3	

17	Q340B06	I型六角螺母	Nut	3	
18	Q40306	弹簧垫圈	Spring washer	3	
19	WG9750580002	Mini 控制器安装支架	Install bracket	1	
20	Q40206	大垫圈	Washer	3	

7.05 70矿车HW7C电器装置/Electrical device



7.05 70矿车HW7C电器装置/Electrical device

序号	零部件图号	名称	Part Name	数量	备注
No.	Part No.			Qty	Remark
4	WG9719584011	灯光开关	Light switch	1	
5	WG9719584112	前雾灯开关	Front fog lamp switch	1	
6	WG9719584113	后雾灯开关	Rear fog lamp switch	1	
7	WG9719584004	危急报警开关	Emer. alarming switch	1	
8	WG9719584115	喇叭转换开关	Horn switch	1	
9	WG9719582007	工作灯开关	Working light switch	1	
10	WG9719582043	前工作灯开关	Working light switch	1	
11	WG9719582012	轴差开关	Switch	1	
12	WG9719584117	排气制动联动切断开关	Exhaust brake linkage to cut	1	
13	WG9900580021	盖板	Plate	3	
14	WG9719582011	轮差开关	Interwheel diff.lock switch	1	
15	WG9719582010	取力器开关	PTO switch	1	
16	WG9719582042	变速箱状态指示灯	Transmission status indicato	1	
17	WG9100580142	24V点烟器	Cigarette lighter (24V)	1	
18	WG9719584020	ECU诊断开关（自复位）	Switch	1	

19	WG9725580005	诊断接口外壳	Cover for diagnosis joint	1	
20	WG9719582098	缓速器开关(常开)	Retarder switch	1	
21	WG9730583117	左组合开关	Combined switch	1	
22	Q2140512	十字槽盘头螺钉	Screw	3	
23	WG9725580013	10A保险装置	Fuse	1	

7.05 70矿车HW7C电器装置/Electrical device



7.05 70矿车HW7C电器装置/Electrical device

序号	零部件图号	名称	Part Name	数量	备注
No.	Part No.			Qty	Remark
24	Q2140512	十字槽盘头螺钉	Screw	3	
25	WG9725584026	线束固定夹	Wireness clip	1	
26	AZ9770584005	发动机ECU&ABS-ECU支架总	Bracket	1	
27	Q340B06	I型六角螺母	Nut	4	
28	Q40306	弹簧垫圈	Spring washer	4	
29	Q40106	平垫圈	Washer	4	
30	AZ9770580003	总支架	Bracket	2	
31	Q40206	大垫圈	Washer	4	
32	Q40306	弹簧垫圈	Spring washer	4	
33	Q340B06	I型六角螺母	Nut	4	
34	WG9725584002	20A常开式继电器	Relay	2	
35	WG9725584003	20A转换式继电器	Relay	1	
36	WG9719582042	变速箱状态指示灯	Transmission status indicato	1	
37	AZ9725580030	橡胶堵盖	Rubber plug	1	

7.07 底盘电器(3个阀/矿车/D20)/Chassis electrical device

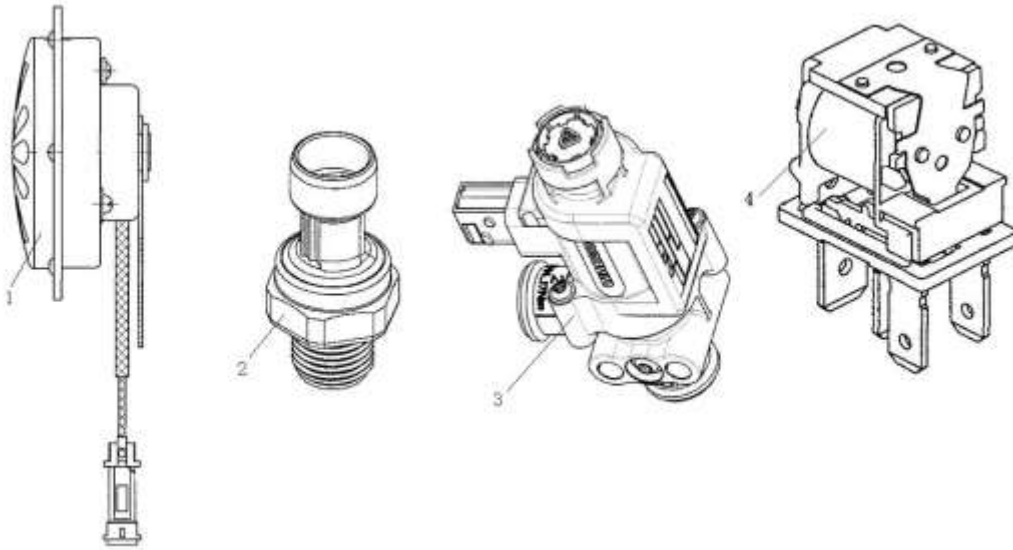

7.07 底盘电器(3个阀/矿车/D20)/Chassis electrical device

序号	零部件图号	名称	Part Name	数量	备注
No.	Part No.			Qty	Remark
1	WG9718710002	盆形电喇叭	Electric horn	1	
2	WG9727710002	电子式气压传感器	Air pressure sensor	2	
3	811W52160-6117	电磁阀	Valve	1	
4	WG9725584002	20A常开式继电器	20A Relay (normally on)	1	
5	Q340B08	1型六角螺母	Nut	5	
6	WG9100710004	气压信号灯开关	Switch-airpressuresignallam	2	
7	AZ9770710001	气压传感器支架	Bracket	1	
8	Q2140620F31	十字槽盘头螺钉	Screw	1	
9	Q2140630F31	十字槽盘头螺钉	Screw	1	
10	Q40306	弹簧垫圈	Spring washer	2	
11	WG9719710004	电磁阀(P99接头)	Solenoid valve	2	
12	Q150B08120	六角头螺栓	Screw	2	

13	Q150B08190	六角头螺栓(螺纹有效长度	Screw	2	
14	Q40308	弹簧垫圈	Spring washer	4	
15	190000810930	铅封线	Lead seal	40cm	
16	Q1460825	六角头螺栓、弹簧垫圈和	Combinationscrew	1	
17	Q2140410	十字槽盘头螺钉	Screw	1	
18	Q40304	弹簧垫圈	Spring washer	1	
19	Q40104	平垫圈	Washer	1	
20	WG9725580086	铅封	Lead sealing	1	

7.08 矿用车前照灯(右置)/Head light



7.08 矿用车前照灯(右置)/Head light

序号	零部件图号	名称	Part Name	数量	备注
No.	Part No.			Qty	Remark
1	WG9719720105	四灯制左前照灯(右置车)	Headlight	1	
2	WG9719720106	四灯制右前照灯(右置车)	Headlight	1	
3	WG9725720001	圆形前雾灯总成	Foglight	2	
4	Q340B06	I型六角螺母	Nut	8	
5	Q40506	重型弹簧垫圈	Spring	8	
6	WG9100720003	左转向信号灯	Indicator lamp	1	
7	WG9100720004	右转向信号灯	Indicator lamp	1	
8	190003699568	簧片螺母	Nut	4	

10	Q150B1650	六角头螺栓	Screw	1	
11	Q150B1660	六角头螺栓	Screw	1	
12	ZQ151B16155TF6	六角头螺栓M16*1.5	Bolt	3	
13	ZQ151B16160TF6	六角头螺栓M16*1.5	Bolt	1	
14	ZQ361B16T13F6	2型六角螺母M16*1.5	Nut	4	
15	I90003888459	自锁螺母	Nut	2	
16	Q40016	小垫圈	Washer	4	
17	WG9100760066	隔板	Plate	1	
18	Q40008	小垫圈	Washer	4	
19	Q33408	1型全金属六角锁紧螺母	Nut	4	
20	I90003179425	堵塞	Plug	4	

7.10 70矿用车电瓶箱/Battery box



7.10 70矿用车电瓶箱/Battery box

序号	零部件图号	名称	Part Name	数量	备注
No.	Part No.			Qty	Remark
21	I90003179425	堵塞	Plug	4	
22	I90003171699	堵塞	Plug	2	
23	Q150B0620	六角头螺栓	Screw	2	
24	I99100760099	密封垫	Gasket	1	
25	Q150B0835	六角头螺栓	Screw	2	
26	Q40308	弹簧垫圈	Spring washer	2	
27	Q340B08	1型六角螺母	Nut	2	
28	I293 130067	橡胶缓冲块	Bumper block	2	

No.	Part No.	名称	Part Name	Qty	Remark
1	AZ9770776207	国III70矿车驾驶室电线束	Cab wiring harness	1	
2	Q41205	外锯齿锁紧垫圈	Washer	3	
3	Q68620	单管夹片	Clip	1	
4	Q150B0616	六角头螺栓	Screw	1	
5	Q40306	弹簧垫圈	Spring washer	1	
6	Q340B06	I型六角螺母	Nut	1	
7	WG1642110018	保护条	Protecting strip	10	
8	WG9725584005	120Ω电阻	120ΩResistance	1	
9	WG9130773002	过线保护盒总成	Protecting box	1	
10	Q2714219	十字槽盘头自攻螺钉	Screw	7	
11	Q340B08	I型六角螺母	Nut	4	
12	Q2140820	十字槽盘头螺钉	Screw	4	
13	Q40208	大垫圈	Washer	4	
14	WG9100770392	分线箱体	Housing	1	
15	179100770391	配电盒	Case	1	
16	Q2762995F31	开槽半沉头自攻螺钉	Screw	3	
17	WG9100770394	分线盒盖	Cover	1	
18	179100770395	电线护套	Sleeve	4	
19	190003120032	圆形密封条	Sealing strips	570mm	
20	Q2713525F31	十字槽盘头自攻螺钉	Screw	4	

7.19 70矿车驾驶室电线(TFT仪表/D20/艾利逊箱/右置)/Cab wiring harness

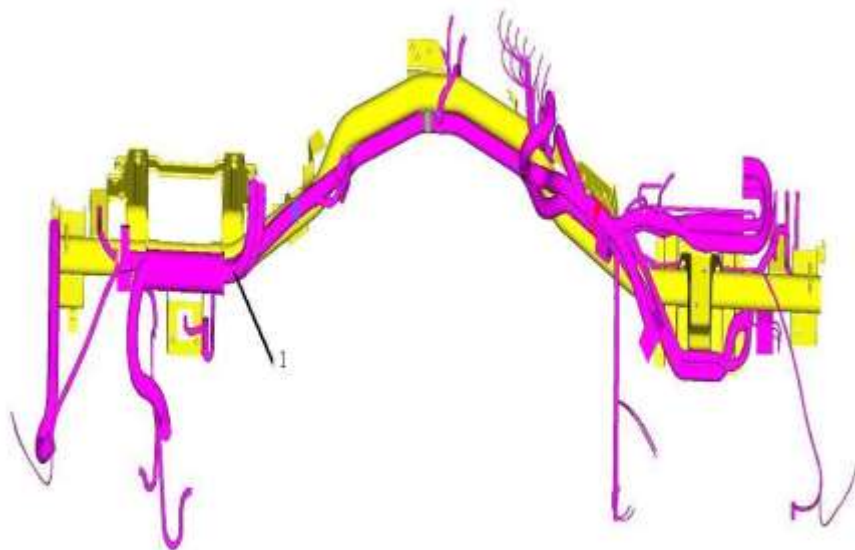

7.19 70矿车驾驶室电线(TFT仪表/D20/艾利逊箱/右置)/Cab wiring harness

7.21 70矿车驾驶室电器设备/ Cab Electric Device

序号	零部件图号	名称	Part Name	数量	备注
No.	Part No.			Qty	Remark
1	WG9725796009	LED示高灯	Show High Lights	3	
2	WG9719720019	矿用车工作灯	Lamp	2	
3	WG9918790001	门灯开关	Switch	1	
4	WG9925720012	侧转向灯(左)	Side turn signal (left)	1	
5	WG9925720013	侧转向灯(右)	Side turn signal (right)	1	
6	WG9719790011	70矿车用内照明灯	Lamp	1	
7	WG9719720019	矿用车工作灯	Lamp	2	
8	Q2714825	十字槽盘头自攻螺钉	Screw	6	
9	Q2764816F31	十字槽半沉头自攻螺钉-C	Screw	1	
10	190003179028	穿线护套	Shield sleeve	100mm	
11	Q2714222	十字槽盘头自攻螺钉	Screw	2	
12	Q39742202	簧片螺母	Nut	2	
13	AZ9770770005	70矿车驾驶室顶蓬电线束	Wireness	1	
14	Q41205	外锯齿锁紧垫圈	Washer	1	
15	190003171697	塑料紧箍带	Cablebinder	5	
16	WG9900580021	盖板	Cover	4	
17	Q340B06	I型六角螺母	Nut	2	
18	Q340B06	I型六角螺母	Nut	2	
19	Q40306	弹簧垫圈	Spring washer	2	
20	Q40306	弹簧垫圈	Spring washer	2	

7.21 70矿车驾驶室电器设备/ Cab Electric Device



7.21 70矿车驾驶室电器设备/ Cab Electric Device

序号	零部件图号	名称	Part Name	数量	备注
No.	Part No.			Qty	Remark
21	Q40106	平垫圈	Washer	4	
22	WG9725796019	30矿车LED示高灯	Show High Lights	1	
23	Q68610F4	单管夹片	Clip	2	
24	AZ1664870055	橡胶垫	Cushion	2	
25	Q150B0618	六角头螺拴	Screw	4	
26	Q40206	大垫圈	Washer	5	
27	Q41206	外锯齿锁紧垫圈	Washer	4	
28	AZ1664870055	橡胶垫	Cushion	2	
29	Q150B0618	六角头螺拴	Screw	4	
30	Q40206	大垫圈	Washer	8	
31	Q41206	外锯齿锁紧垫圈	Washer	4	
32	190003179028	穿线护套	Shield sleeve	540mm	
33	WG9725720007	侧转向灯线束支架	Bracket	1	
34	WG9725720007	侧转向灯线束支架	Bracket	1	
35	WG97 350169	角形支架	Bracket	2	
36	WG9725796009	LED示高灯	Show High Lights	1	
37	Q2140516	十字槽盘头螺钉	Screw	2	
38	Q40005	小垫圈	Washer	2	
39	Q40305	弹簧垫圈	Spring washer	2	
40	AZ9725773208	30矿车右LED示高灯电线束	Wireness	1	

7.22 带侧标志灯的组合后灯/Combination lamp



